

Operating and assembly instructions



**Euroroll Flow Beds
for cartons & boxes**

Introduction

For the safe operation and use of flow beds some skills are required, which are mediated by these operating instructions.

Some basic instructions and information to operate a flow bed are listed below:

Delivery, storage, installation and picking, as well as ongoing operation, safety, maintenance, troubleshooting, waste disposal and decommissioning-acquisition.

This instruction manual is tied to a specific production process, a product or a workplace. It should be an auxiliary tool for all users, so that they can carry out their tasks with the required quality.

A proper functionality and a trouble-free flow of a flow bed is only possible and guaranteed, if a load support is used, which corresponds to the standards and the technical specifications.

Before using the flow bed by the user, the instructions in this manual must be strictly observed to ensure that a safe operation is guaranteed. Failure to comply with these operating instructions will invalidate our warranty.

If you have any further questions, please feel free to contact us by email: info@euroroll.de or by calling Tel.: +49 (0) 2599 -92503-0. Our employees would be more than happy to provide you any information and give you technical assistance.

Manufacturer:
Euroroll GmbH
An der Vogelrute 46b-50
D-59387 Ascheberg-Herbern
E-Mail: info@euroroll.de
Tel.: +49 (0) 2599 -92503-0

Download: <http://www.euroroll.de/downloads.html>

Table of Contents

Flow Bed Operating and Assembly Instructions

1. Safety

- 1.1 Basic warnings and symbols
- 1.2 Specific safety instructions for flow beds
 - 1.2.1 Intended use
 - 1.2.2 Foreseeable misuse
(A usage not according to the intended purpose)
 - 1.2.3 Directive of the storage facilities and devices BGR 234
- 1.3 Use of qualified employees
- 1.4 Hazard labelling

2. Technical description of flow beds

- 2.1 General system description
- 2.2 Flow beds types
 - 2.2.1 FIFO Standard
 - 2.2.2 FIFO with picking tray (8°)
 - 2.2.3 FIFO with picking tray (15°) Drop Out Box
 - 2.2.4 LIFO Standard
 - 2.2.5 LIFO with picking tray (8°)
 - 2.2.6 LIFO with picking tray (15°) Drop Out Box
- 2.3 Technical characteristics of flow beds

3. Components of flow beds

- 3.1 Side profile
- 3.2 Rear-side profile (loading)
- 3.3 Front-side profile (unloading)
- 3.4 Beams
- 3.5 Picking tray 8°
- 3.6 Picking tray 15° Drop Out Box
- 3.7 Shelf mounting (Universal adapter)
- 3.8 Fixing clips
- 3.9 End caps
- 3.10 Locking bar
- 3.11 Bolts and nuts M10
- 3.12 Bolts and nuts M8
- 3.13 Supporting construction

4. Assembly and installation

- 4.1 General mounting and installation instructions
- 4.2 Delivery and storage
- 4.3 Installation sequence

5. Initial start-up

- 5.1 Measures before initial start-up
- 5.2 Commissioning
- 5.3 Commissioning with load
- 5.4 Ongoing operation
- 5.5 Loading

6. Cleaning, Maintenance and Repair

- 6.1 Cleaning
- 6.2 Note on maintenance and repair work
- 6.3 Maintenance and inspection list

7. Decommissioning

8. Spare parts

9. Residual risks

Annex

Drawings

Copyright as per DIN ISO 16016

1. Safety

The basic warnings are explained below. These will be mentioned in the course of the operating and assembly instructions and will serve to highlight potential sources of danger. Furthermore, in this chapter you can find specific safety instructions for flow beds, as well as instructions for its intended and not intended use.

1.1 Basic Warnings and symbols



Group risk

These instructions must be followed to avoid damage to persons.



Group warning

These instructions must be followed to avoid damage to persons, to the product or to the environment.



Group Caution

These instructions must be followed to avoid damage to the product.



Group instructions

These instructions give further information regarding the use of carton flow beds.

1.2 Specific safety instructions for flow beds

A flow bed can be a danger in everyday use, even if it was mounted according to the latest technology:

A necessary condition for the safe handling and trouble-free operation of the flow bed is the knowledge of the following safety tips. In addition, the technical rules of a safe and professional work must be followed, as well as the pertinent on-site regulations for accident prevention.

Failure to follow the instructions in this manual may lead to serious injuries, possibly even resulting in death. Please read these operating instructions carefully and stick to the safety regulations.

The safe and trouble-free operation of the flow bed can be ensured only with regard to this manual.

The use of the flow bed must be only entrusted to qualified personnel with appropriate training. Ensure that this manual is kept accessible for all those near the operation site. Ensure that the legal requirements are always met in your company.

1.2.1 Intended Use

The storage facilities and equipment must be designed and placed, that they can safely bear the load of the stored material when it is used.

Their stability and structural safety must fulfil the operational loads and be proved by calculated verification of load-bearing capacity limit for the loaded elements or by loading tests.

All other uses not as intended are forbidden!

The correct use of the flow bed includes:



- Observe the safety instructions.
- Perform prescribed setup work.
- Perform prescribed maintenance measures.
- Note the technical data.
- For damages resulting from non-intended use, the manufacturer assumes no liability.
- In case of replacing defective parts, only original spare parts or those ones approved by the manufacturer must be used.
- Adhere to the manufacturers or supplier removal and installation instructions when replacing.
- The operation, maintenance and repair instructions contained in this manual are mandatory.

1.2.2 Foreseeable misuse

(A usage not according to the intended purpose)

- The flow bed must be used accordingly to these operating instructions. Any other or exceeding use not as intended will invalidate the warranty claim.
- Changes of all fittings, screws and functional components are only allowed with the agreement of the manufacturer.
- No original spare parts will be used.
- The flow bed is not built according to specifications.
- The flow bed is not to be used for passenger transport and neither for the transport of bulky items.

1.2.3 Directive of the storage facilities and devices BGR 234

The storage facilities and equipment must be designed and placed that they can safely bear the load of the stored material when it is used as intended. Their stability and structural safety must fulfil the operational loads and be proved by calculated verification of load-bearing capacity limit for the loaded elements or by loading tests.

The storage facilities and storage equipment shall be designed, operated and tested in accordance with this BG Rule and in accordance with the generally recognized rules of technology. Deviations are permissible if the same degree of safety is ensured in some other way.

1.3 Use of qualified employees





Qualified personnel are persons who have a job corresponding to their education and experience and knowledge of the relevant standards and regulations, accident prevention regulations and operating conditions. They must have been authorized by the person responsible for the safety of the flow rack bed framework to carry out the necessary work and thereby be able to recognize potential hazards and avoid them.





1.4 Hazard labelling

The signs described below can be attached to the conveyor system and contain important safety and operating information.

These signs belong to the equipment of the conveyor system and they must not be removed!

Illegible signs must be replaced immediately!

	<p>Attention! Have you read the operating instructions - in particular the "Safety" section? Do not operate the system before that.</p>
	<p>Attention! Maintenance, cleaning and repair work must be only performed by authorized staff.</p>
	<p>Attention! Only trained, authorized and reliable staff can exclusively work with the system. It must be ensured, that the trained staff that is working with it, has read and understood the operating instructions, especially the safety instructions and residual risks.</p>
	<p>Attention! Conversions and deactivation of protective devices can cause serious injuries. Never modify or disable them unauthorized. Extensions, alterations and improvements can be only made by trained and authorized staff.</p>

	<p>Attention! Only trained and authorized staff can perform the construction.</p>
	<p>Protect the environment! Handling and disposal of cleaning materials are subject to legal regulations. Deliver the impregnated substances with cleaners or wipes only to authorized collection points. The accurate information is provided by the competent Office for Water Management or trade board. Do not spill cleaners! Take precautions to collect or to bind spilled cleaners.</p>
	<p>Attention! The dismantling and disposal can be carried out only by authorized staff.</p>
	<p>Protect the environment! The handling and disposal of old devices are subjected to legal regulations.</p>

2. Technical Description of flow beds

Below it will be a short system description to explain the different flow beds. Furthermore, the standard dimensions, distances and other technical characteristics of profiles and roller tracks will be indicated.

2.1 General System Descriptions

Euroroll flow bed is distinguished as a pluggable, flexible and economic system, which guarantees a quick and smooth picking of cartons and boxes. It is possible to manufacture the flow beds in any width up to 3.600mm and depths up to 5.000mm.

The general system description looks as follows:

- **Flow bed:** the system components includes extraction profile, traverses, universal adapter, bolts, end plugs, screws, roller tracks and guide rails
- **Width:** Standard 1400mm / 1800mm / 2200mm / 2700mm / Maximum width: 3600mm
- **Depth:** Standard 1237mm / 2459mm / Maximum depth: 5000mm
- **Rear-side profile unloading:** straight / with picking tray 8° or 15°
- **Front-side profile loading:** straight
- **Installation and connection:** with locker (screw solution by request)
- **Connection with shelving systems:** Euroroll universal adapter or direct
- **Wheel Rail:** in versions AN, N, SP, Nmini and SF (ESD for N program)
- **Guide rail:** in Standard (AFU), round for narrow guidance (RFÜ) and entry guides

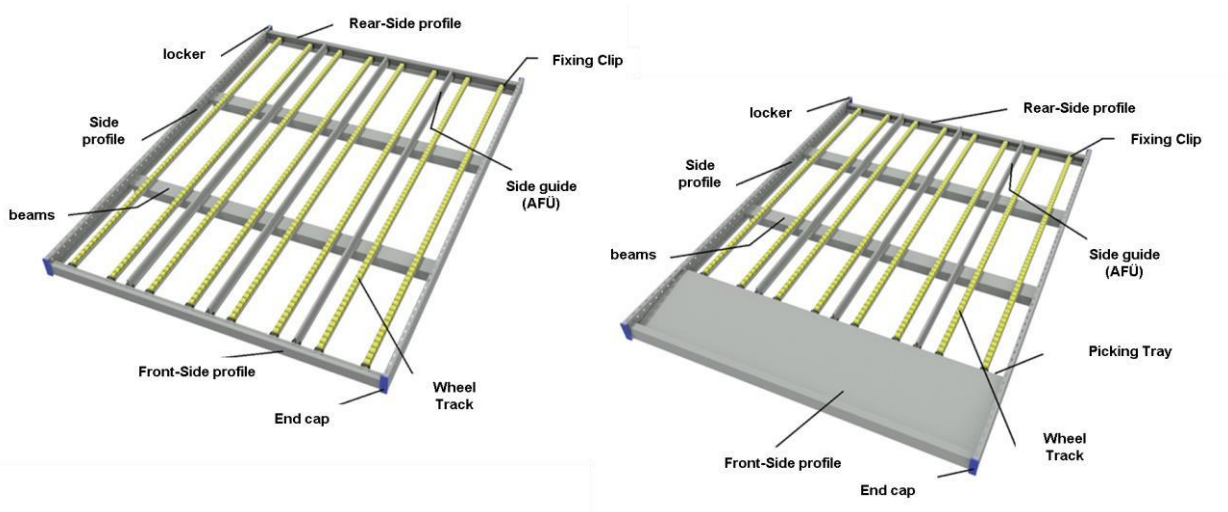

2.2 Flow bed types

There are several types to be distinguished from each other. These types differ either in the loading or the unloading as a general rule. Therefore, the different types of loading and unloading are shown below:

2.2.1 FIFO Standard

The FIFO standard flow bed includes a straight running picking area on both loading side and unloading side.

The frame profile of the loading side is at the rollers level and allows a comfortable loading of goods. The frame profile at the unloading side is elevated and acts as an end stop.

Loading Standard (Rear-side profile)

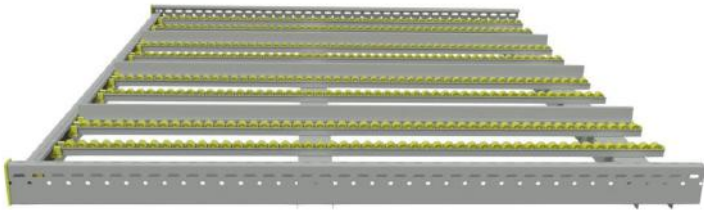

The loading standard includes a rear-side profile which is located at the roller level.

Profile height: 68mm

Profile width: 37mm

(Simultaneous storage surface)

Connection to the side profile through locking bar

Unloading Standard (Front-side profile)

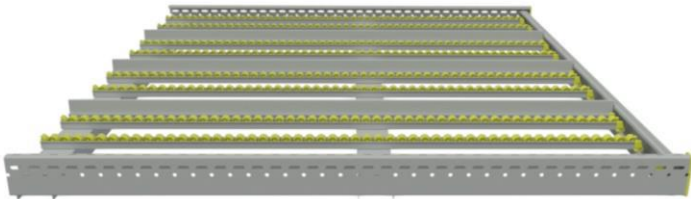

The unloading standard includes an elevated front-side profile which acts as an end stop and is 15mm over the rollers.

Profile height: 86mm

Profile width: 30 mm

Connection to the side profile through locking bar

2.2.2 FIFO with picking tray 8°

The FIFO flow bed with picking system does not differ on the loading side from the standard FIFO flow bed. The straight outgoing picking area will be replaced with an 8° inclination picking steel tray on the unloading side. This one has a depth of 400mm and allows the best possible access to the stored goods and optimizes the commissioning.

Unloading picking tray

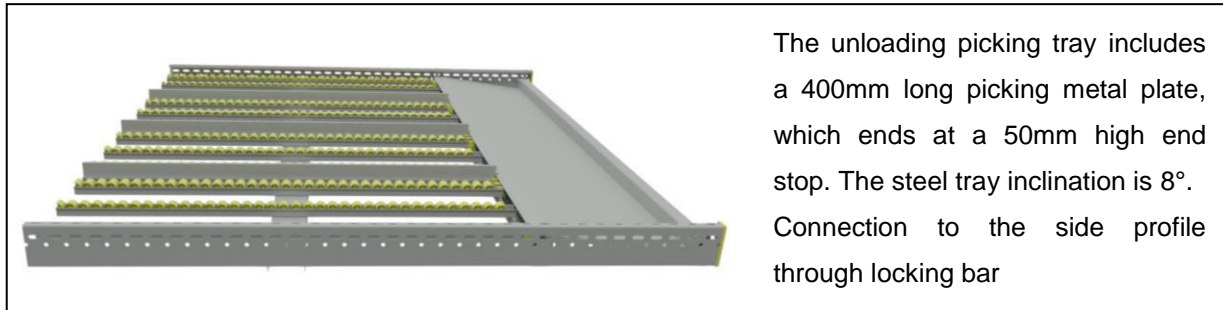

2.2.3 FIFO with picking tray (15°) Drop Out Box

The FIFO flow bed with picking system does not differ on the loading side from the standard FIFO flow bed. The straight outgoing picking area will be replaced with a 15° inclination picking storage place on the unloading side. This one has a depth of 400mm and allows the best possible access to the stored goods and optimizes the commissioning.

Unloading FIFO

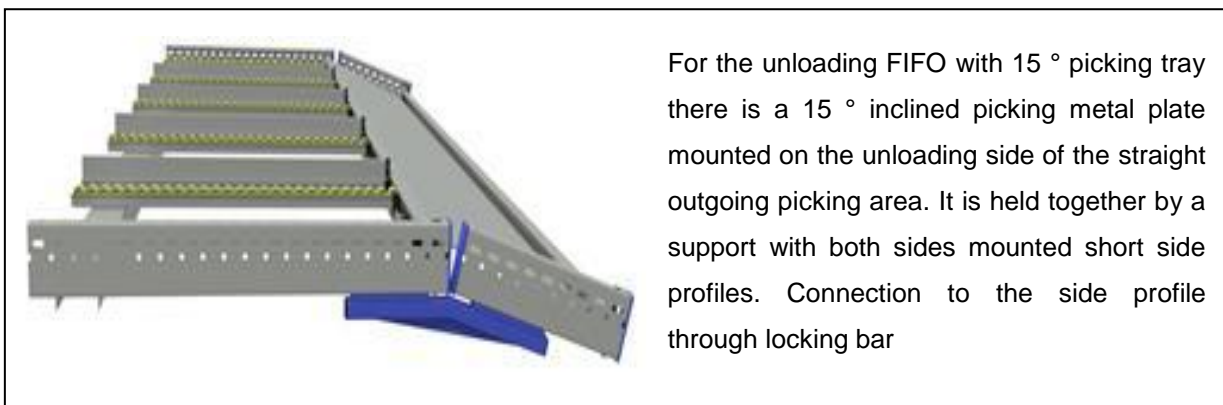

2.2.4 LIFO Standard

The LIFO standard configuration differs to the FIFO standard only by the loading profile, because in a plug-in system (LIFO) two end stops must be provided (so that the carrier cannot be pushed out of the system).

The loading profile of the LIFO standard system is therefore identical to the unloading profile and acts as an end stop.

Loading LIFO

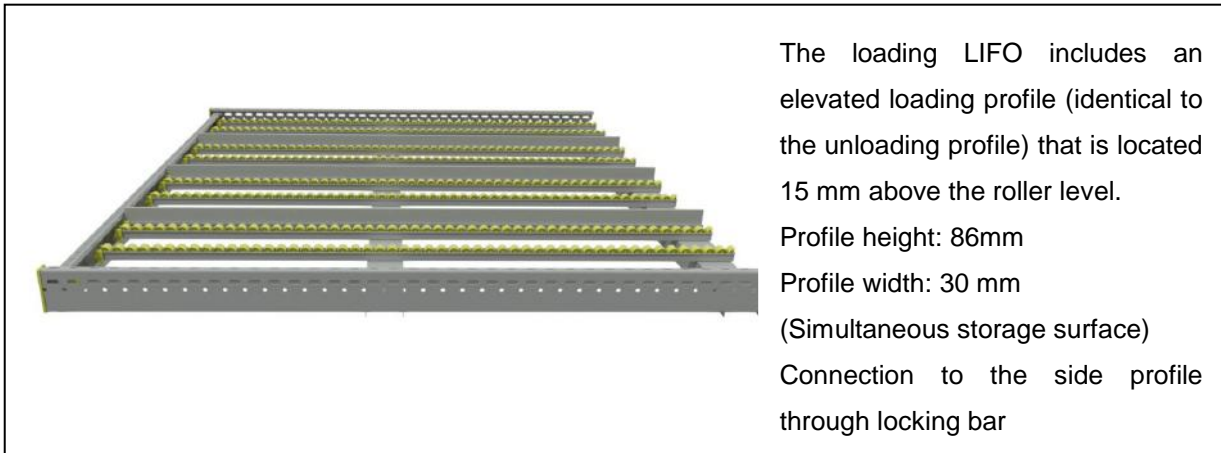

2.2.5 LIFO with picking tray 8°

The LIFO system with picking storage space includes an elevated loading profile (see 2.2.4) and a picking tray 8° (see 2.2.2) and it is a combination of these two systems.

The LIFO flow bed with picking system does not differ on the loading side from the standard LIFO flow bed. The straight outgoing picking area will be replaced with an 8° inclination picking steel tray on the unloading side. This one has a depth of 400mm and allows the best possible access to the stored goods and optimizes the commissioning.

2.2.6 LIFO with picking tray (15°) Drop Out Box

The LIFO flow bed with picking system does not differ on the loading side from the standard LIFO flow bed. The straight outgoing picking area will be replaced with a 15° inclination picking storage place on the unloading side. This one has a depth of 400mm and allows the best possible access to the stored goods and optimizes the commissioning.

Unloading LIFO with picking tray

Unloading side

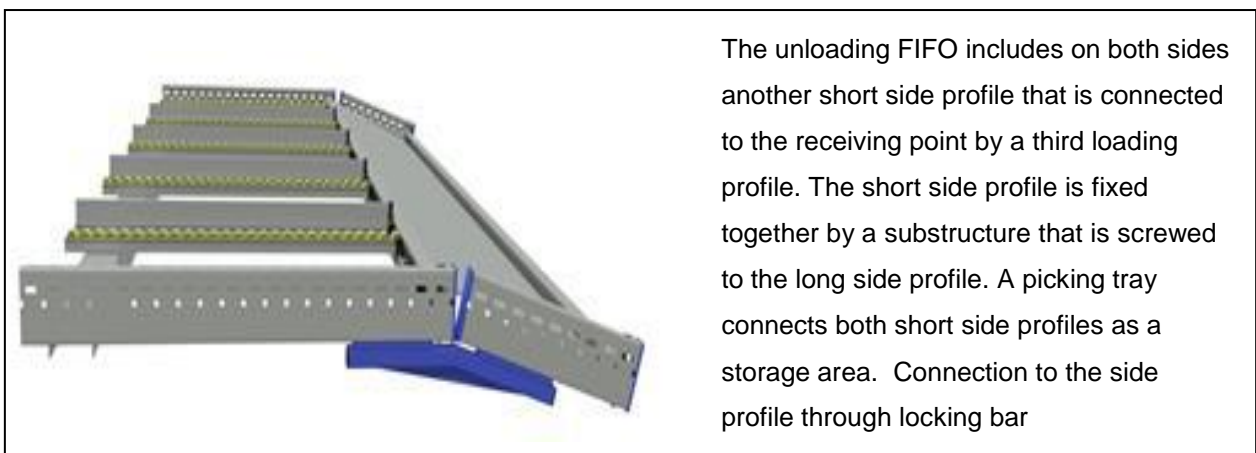

Loading side LIFO

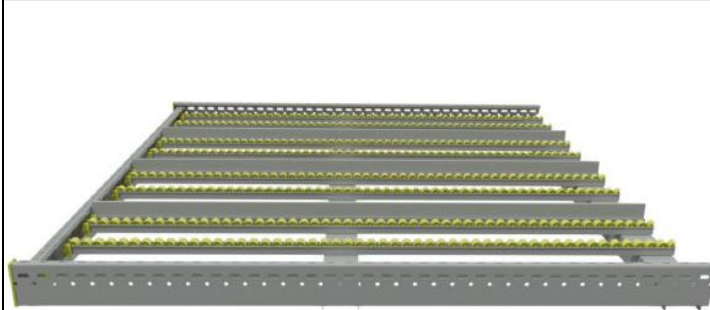

The loading side includes a higher loading profile (identical to the unloading profile) which is 15mm above the roller upper level.
(In order to avoid that the carrier fall out of the system)
Profile height: 86mm
Profile width: 30 mm
(Simultaneous storage surface)
Connection to the side profile through locking bar

2.3 Technical characteristics of flow beds

Below are important technical characteristics about the Euroroll flow rack bed, which are related primarily to the operation and use of the systems. In this regard the following characteristics must be differentiated from each other:

Characteristics of flow beds:

- **Weight** Up to 200 kg / m²
- **Slope** The slope should be adjusted on site customized for each individual carrier and its weight.
Euroroll system offers adjusting possibilities in a hole grid of 25 mm. In most cases is the slope between 5% -7.5%
- **Loading / unloading** Unless it is not specified in an Euroroll offer, both loading and unloading must be accomplished by hand.
- **Carrier / load unit** The carrier used must have an inherent rigidity and be able to roll. It is particularly not allowed that the used weight block or dirty the flow bed and due to its composition the flow rack bed be oxidized or damaged.
- **Conductivity:** Euroroll Standard flow beds and wheel rails are not designed to work with electrostatically charging products. If necessary, the wheel rails can be delivered in a highly conductive version. In addition, the whole flow beds and racks must be separately grounded.

Environmental factors:

- **Surroundings** The environment, in which the flow bed is located, must not have the following load characteristics:
Radiation, decomposition, vibrations, corrosion and similar.
- **Ambient temperature** The Euroroll flow beds are designed to operate at a temperature in the range of -28 ° C to + 40 °
- **Humidity** The maximum humidity must not exceed 80%.

3. Components of flow beds

In addition to the different versions of flow beds, all the system components in its function and characteristics are briefly described below.

3.1 Side Profile

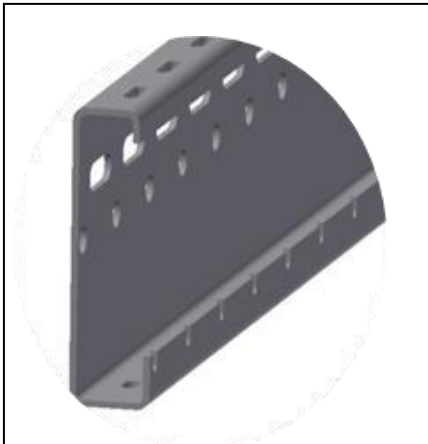

The side profile serves as a connection to the shelving or racking system and the outer guide of the transported material. It also supports the unloading and loading profile, as well as the beams.

Profile height: 110 mm
Top width: 25mm
Down width: 30 mm

3.2 Rear-side profile (loading)

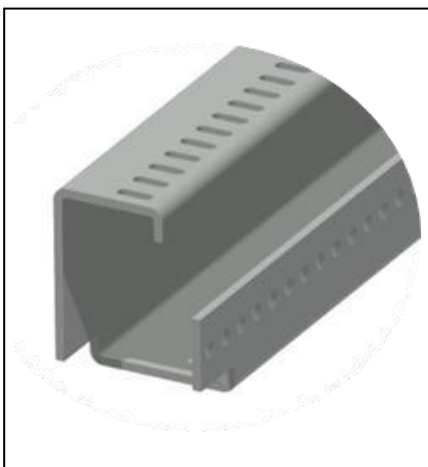

The loading profile is used for the circulation of the transported materials and the loading channels. Also entry guides can be mounted here. It forms a direct connection to the side profile and is connected through the locking bar. Furthermore, it forms the loading for the mounting clips of the wheel rails and guide rails (AFÜS).

Profile height: 68 mm
Top width: 37mm
Down width: 50 mm

3.3 Front-side profile (unloading)

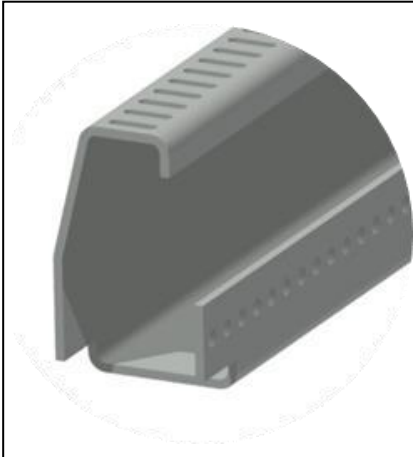

The unloading serves as an end stop for the transported material. In LIFO systems this profile is also used as loading profile. With the help of the locking bar the unloading profile is connected to the side profile. Even the unloading profile serves as loading of the fastening clips for roller tracks and guide rails.

Profile height: 86 mm

Top width: 30 mm

Down width: 50 mm

3.4 Beams

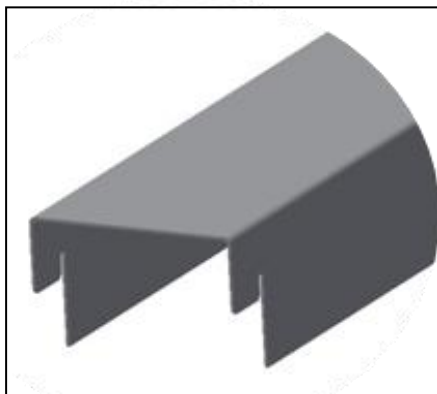

The beams stabilize the flow bed. Different numbers of beams can be used depending on the load and the system depth. With the help of the clinch, the traverses can be connected to the side profile.

Profile height: 65 mm

Profile width: 94 mm

3.5 Picking tray 8°

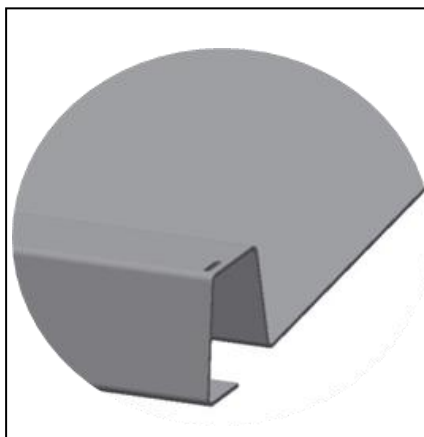

The picking tray supports a comfortable picking process. An additional loading profile forms both the receiving point of the wheel rails and the guide rails as well as the connection point to the picking plate. This is fixed with additional locking bar at the side profile.

Depth: 400mm

Inclination: 12°

3.6 Picking tray 15° Drop out Box

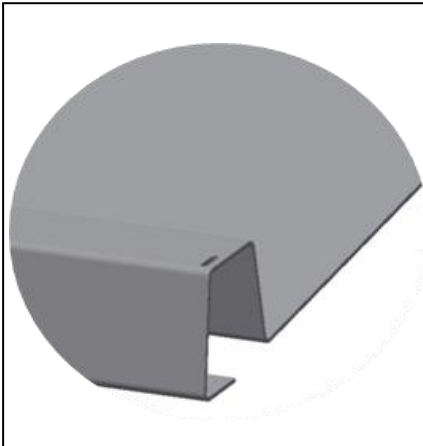

The picking tray supports a comfortable picking process. The drop-out box is installed by using a substructure as a separate item on the flow bed.

Depth: 400mm

Inclination: 15°

3.7 Shelf mounting (Universal adapter)

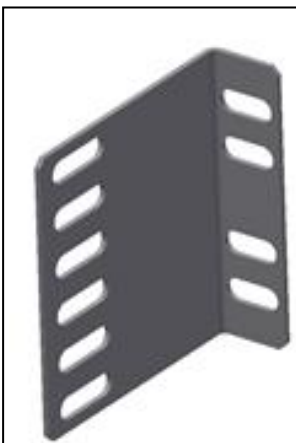

The universal adapter allows the connection of the flow bed with different shelving systems. It is connected to the shelving or racking system with the long holes in the short bar (25mm distance). Through the 25 mm distance, the current slope between 1.25% and 10% can be generated.

Profile height: 65 mm

Profile width: 94 mm

3.8 Fixing clip

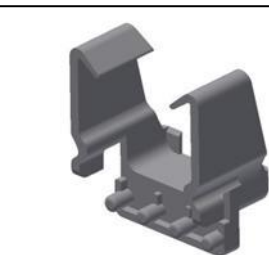

The fixing clip serves as connection unit for the wheel rails and guide rails/ side guides. It is fixed in the pitch pattern of the loading and unloading profile and provides a solid, fix and sure support to this one.

3.9 End caps



The end cap is attached at each end of the side profiles and serves as edge protection to avoid hazards such as cuts.

3.10 Locking bar



The locking bar is used to attach the profiles with each other and provides a robust and reliable connector. It forms the connection between the side profile and loading or unloading profile or picking shelf profile. Alternatively, a screw connection can be ordered upon request.

3.11 Bolts and nuts M10



Euroroll flow beds use M10 bolts, washers and lock nuts by default. These ones form the connection between universal adapter and racking system as well as between universal adapter and flow bed.

3.12 Bolts and nuts M8



Euroroll flow beds use M8 bolts with washers for the connection between the substructure and the side profile and as well as for the side profile drop-out

3.13 Supporting construction



The substructure is mounted on both sides of the side profiles.
In another step, the substructure also serves as a holder for the picking storage place as well as for the drop-out side part

4. Assembly and installation

Hereinafter, the installation of the flow bed on the shelf will be gradually demonstrated. In addition, it will be information about delivery and storage as well as important instructions for installation.

4.1 General Assembly and Installation Instructions

Attention: The supplied fitting drawing of the flow bed must to be used for installation support.



Caution!

- The installation can be only be performed by trained, authorized specialists and companies.
- Make sure that the loading direction is followed. Note type of loading in the flow level (LIFO or FIFO)
- Do not insert any carrier into the DLR, if they cannot be inserted.
- Do not apply pressure on the storage of the carriers.
- If a carrier steps out the flow level, this one must be immediately removed.



Risk of injury!

The fastening bands of the transport units are under tension. Wear gloves and safety glasses when opening!



Instructions in case of improper handling

- In case of visible damage of the carriers, the DLR must be immediately blocked and clearly labelled.
- Do not insert carriers in the unloading side, if there is not enough space in the flow rack level.
- If a carrier stops, clarify the causes and remove the carriers from the DLR.
- If a carrier stops at the same place, maintenance must be informed in order to take appropriate action (causal research).
- In case of damage caused by collision with the rack supports, the flow rack levels or the wheel rails, maintenance must be informed.
- If some components such as screws or nuts, as well as other metal parts have been discovered at the flow rack level, all adjacent flow levels must be checked. They must be immediately stopped and clearly marked.

4.2 Delivery and storage

Flow beds are in each case transport units. Each unit can be transported with forklift truck or hand pallet truck to the point of use. It must be observed the minimum carrying capacity of the transport and lifting equipment according to the weight of the package. The flow beds must be checked for

completeness and possible transport damage immediately at receipt. In case of complaints, the manufacturer must be immediately informed in writing of the damage and in case of damage during the transport also the freight forwarder. The storage area must be dry and protected from dust, dirt and vibrations. The packages are not suitable for outdoor storage. If they are stored outdoors, additional measures for the protection against adverse weather conditions need to be provided.

4.3 Installation sequence

All the components required for the assembly of the flow bed can be found in the drawing. Depending on the arrangement and complexity is also an installation drawing available.

Preparing the installation:

Before starting the installation it is recommended to note the following points to ensure a smooth installation process.

- Inspection of supplied parts using the parts list
- Separate storage of each flow rack bed
- Inspection of the flow bed drawing
- Inspection of the installation drawing (if included)
- We recommend first to build a flow bed or even a complete rack module to determine an optimal slope for the respective carrier / weight.
- Follow the ground conditions

It is recommended to store the components for each flow rack bed together:

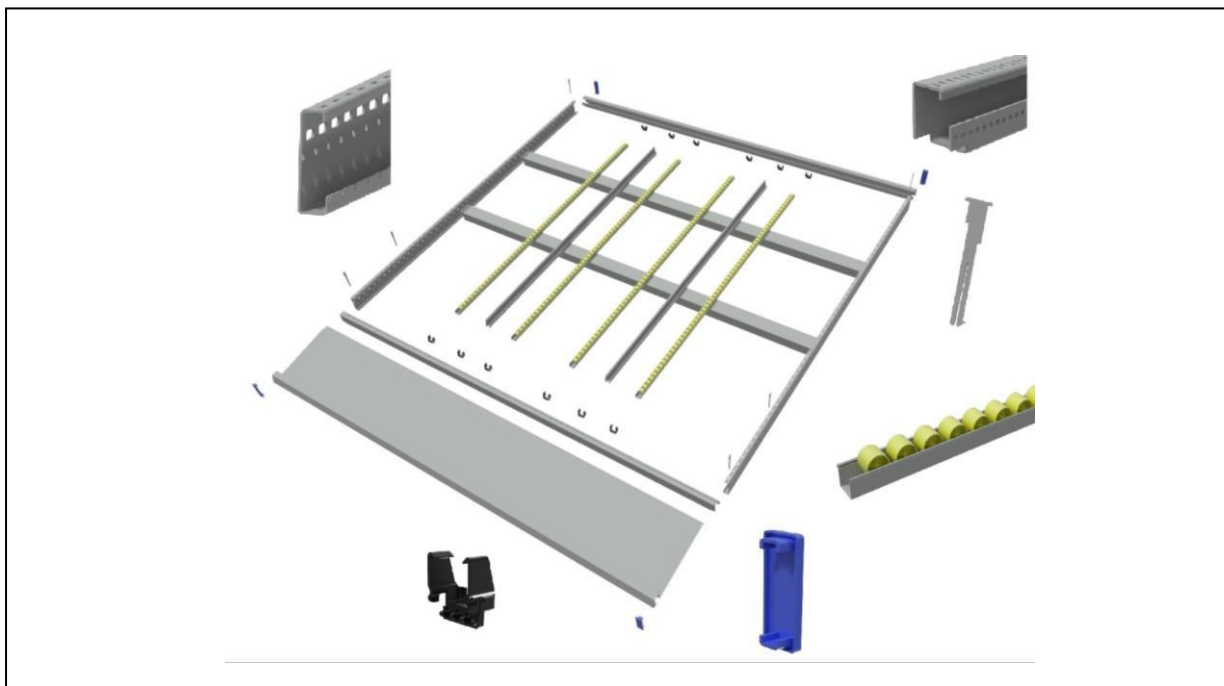

After the preparation begin the start of the assembly. In this regard the installation of a flow bed (for different versions) will be explained step by step.

Step 1 Installation with universal adapter or direct connection to a shelving system.

Variant 1 Installation of the universal adapter on a shelf system.

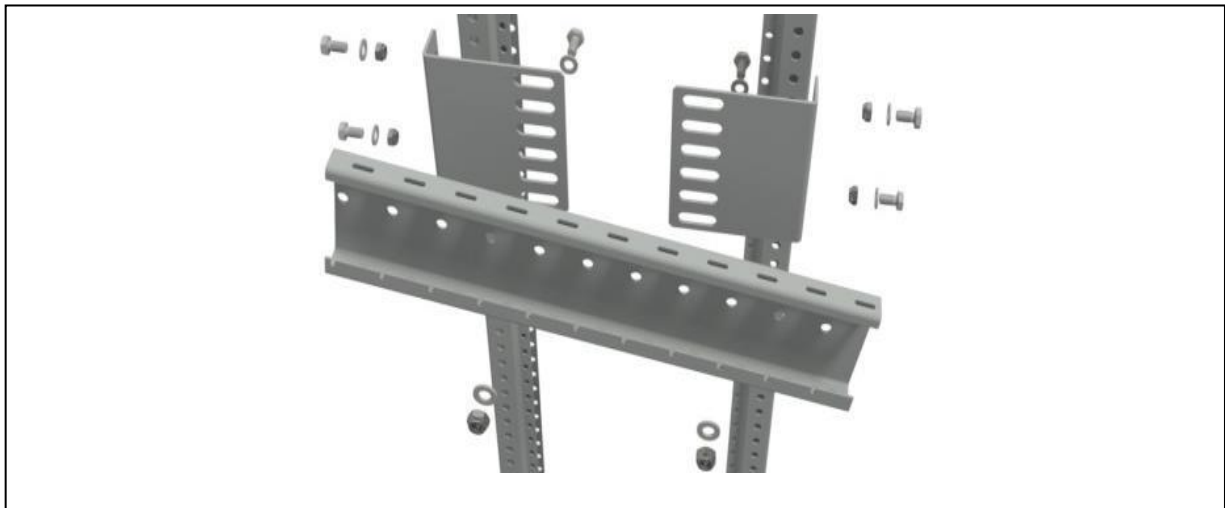

The universal adapter can be installed on any conventional racking system. In particular you should be observed. Keep the following in mind!

- The number of universal adapters per flow bed level must be strictly followed. (see enclosed flow bed drawing)
- The universal adapters have to be fixed uniformly and symmetrically on the loading and unloading side of the flow rack bed.
- By installing the universal adapter, the desired slope of the flow bed is defined.
- The universal adapter is connected to the racking system through the long holes in the short bar (25mm distance).
- The universal adapter is connected to the flow bed through the long holes in the long bar (25mm distance)
- Be sure to use the supplied M10 bolts, as well as the corresponding washers and lock nuts.

Variant 2 Installation of the side profile to a shelving system (without adapter)

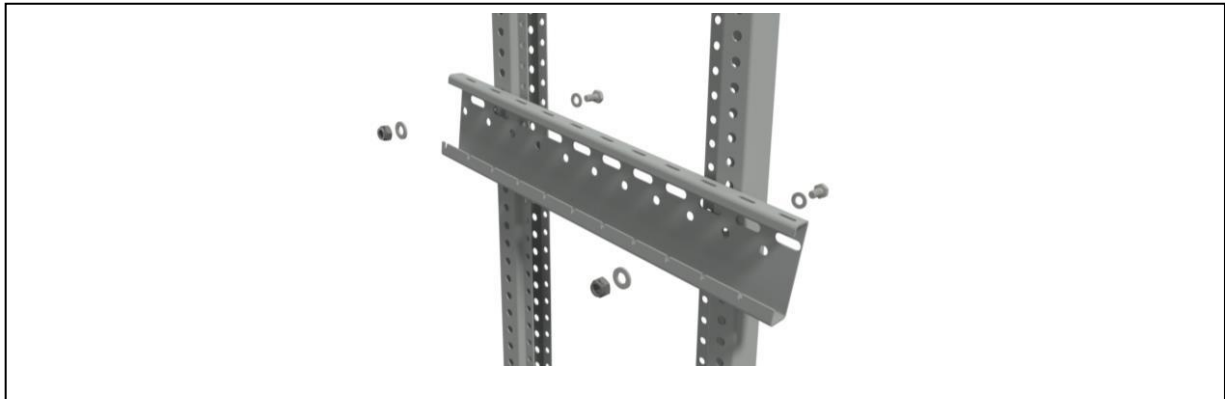

In this version, the side profiles can be installed on certain shelf systems without the universal adapters. Keep the following in mind!

- In the loading area the side profile is mounted with the available round hole on the shelf stand.
- In unloading area the side profile can be adjustable fitted with the existing long and round holes.
- Be sure to use the supplied M10 bolts, as well as the corresponding washers and lock nuts.
- Of particular note is that the side profiles are mounted higher on the loading side than on the unloading side to achieve a corresponding slope. The gap is usually from 5% to 7.5%. This should be exactly determined by testing.

Step 2 Installation of the loading profile (rear-side profile)

Variant 1 Rear-side (loading) FIFO flow bed system

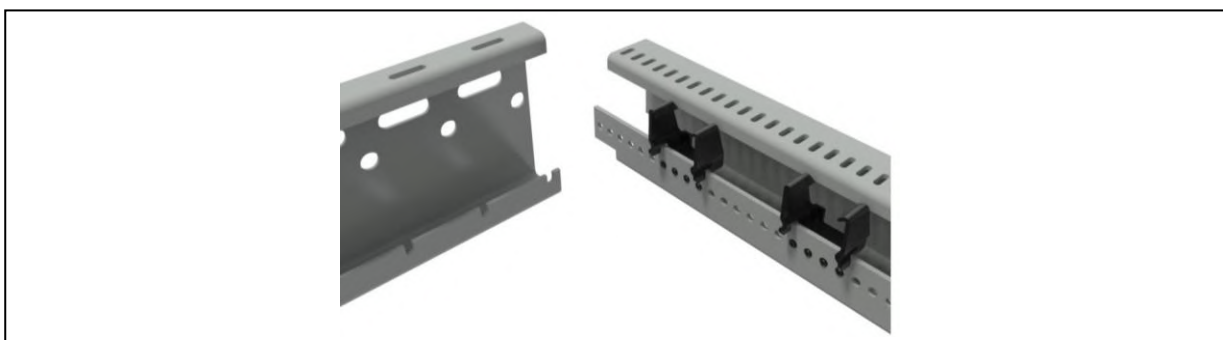

The clips are fitted first in the specified grid inside the loading profile (rear-side profile).

The loading profile (rear-side profile) is inserted in the 1st and 2nd groove of the side profile with the already built-in fastening clips on both sides, and it is fixed with the supplied bolts. Furthermore, both side profiles are closed with the end plugs on the loading side.

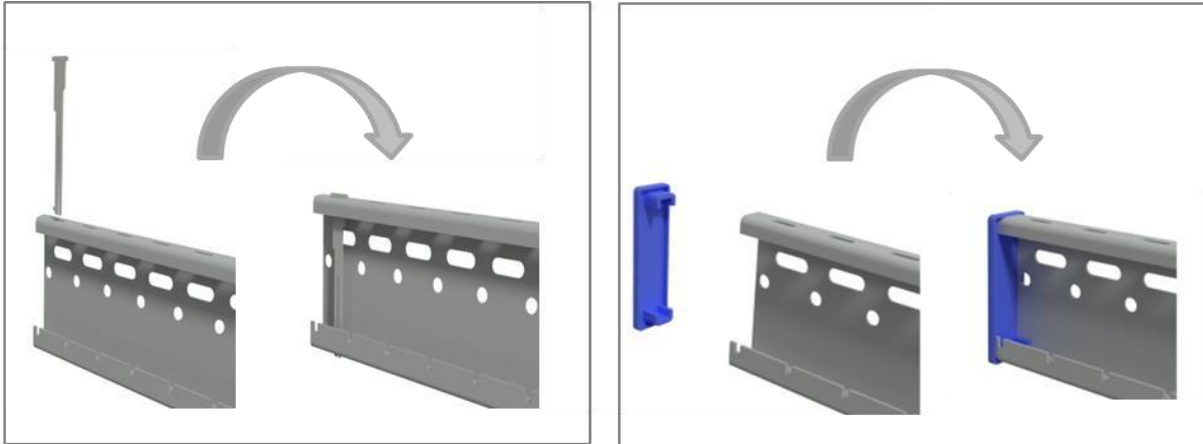

Variant 2 Loading for push-back LIFO

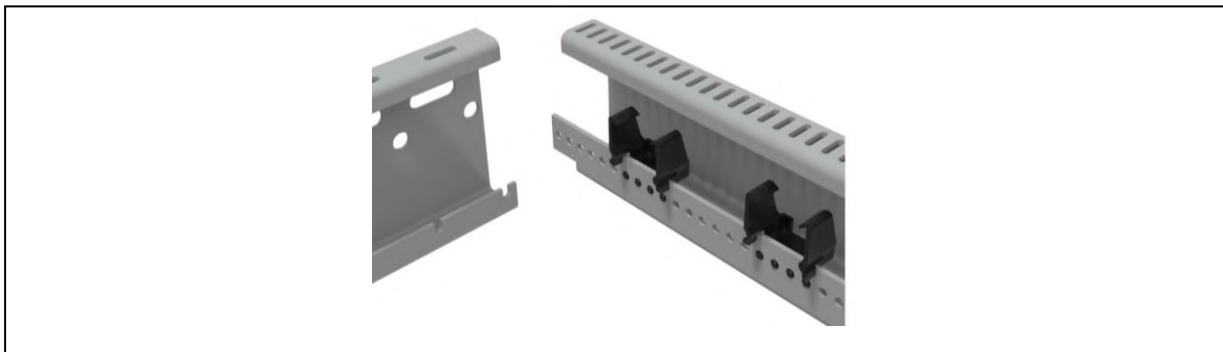

The fastening clips are fitted first in the specified grid inside the loading profile. (Info: by LIFO use are loading and unloading profiles identical).

The loading profile is inserted in the 1st and 2nd groove of the side profile with the already built-in fastening clips on both sides and it is fixed with the supplied bolts.

Furthermore, both side profiles are closed with the end plugs on the loading side (See variant 1).

Schritt 3 Installation of beams

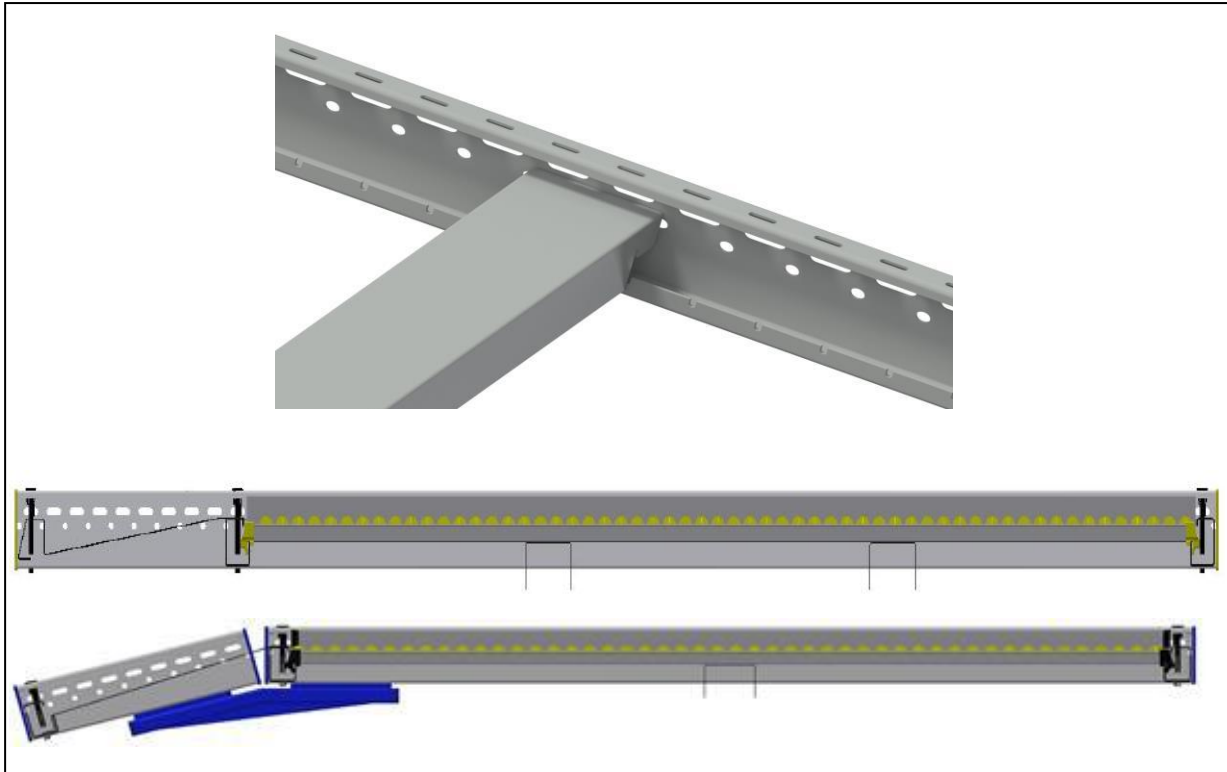

The incorporated beams are inserted into the slots of the side profiles. This procedure is equally provided for all flow beds variants.

Note: the number of incorporated beams inside the bed level is submitted in the supplied flow bed drawing. The distance between the traverses should be evenly distributed on the whole frame depth.

Step 4 Installation of the unloading profile (front-side profile)

Variant 1 Standard unloading

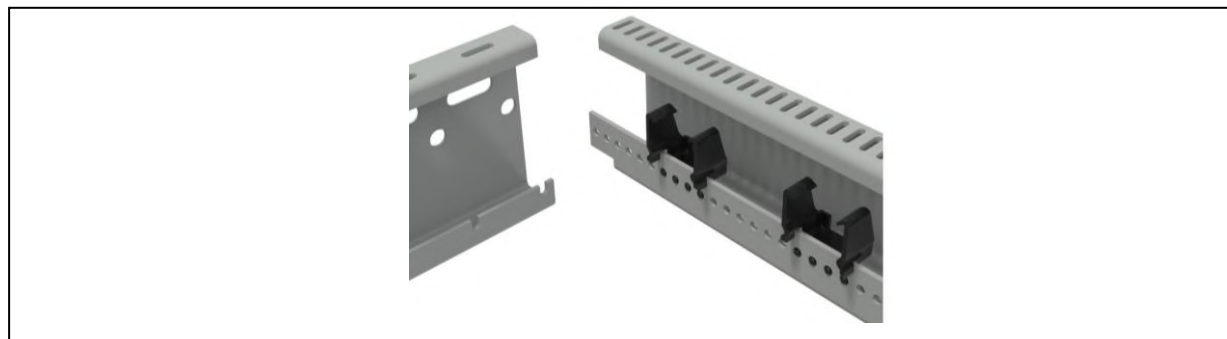

The clips are fitted first in the specified grid inside the unloading profile (front-side profile).

The unloading profile (front-side profile) is inserted in the 1st and 2nd groove of the side profile, with the already built-in fastening clips on both sides and is fixed with the supplied bolts. Furthermore, both side profiles are closed with the end plugs on the unloading side (see step 2 variant 1).

Variant 2 Unloading picking tray 8°

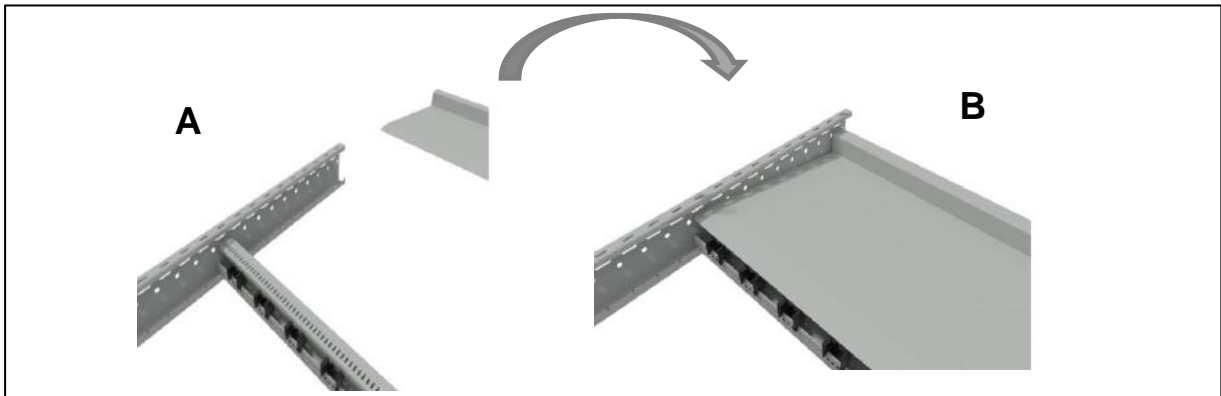

In the step A the unloading profile is inserted into the grooves of the side profile in the corresponding distance. In the step B the picking plate is inserted appropriately. (Exact dimensions can be taken from the flow bed fitting drawing).

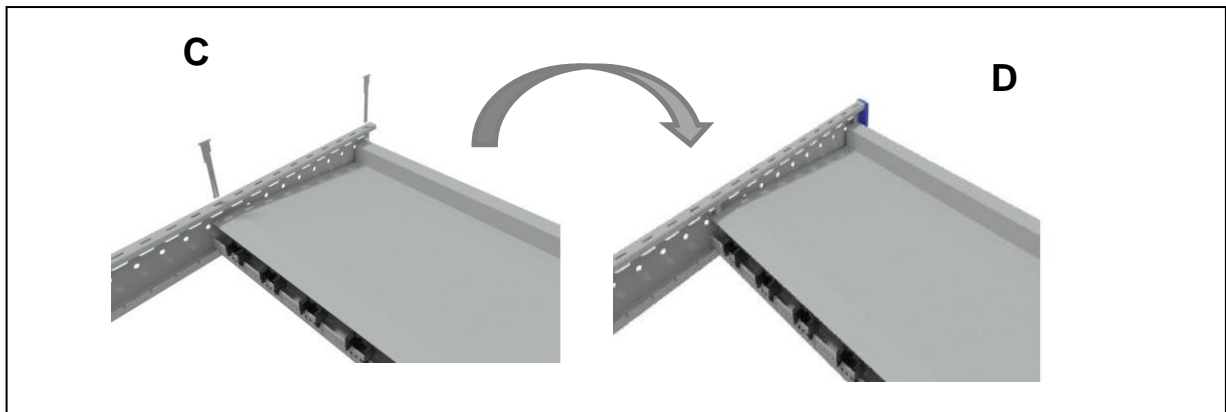

In the step C the locking bars are used at both ends to fix the picking metal sheet into the corresponding grooves. In the step D both end plugs are inserted into the side profile.

Variant 3 Unloading picking tray 15° Drop Out Box

Installation of supporting construction 15° with side profile drop out box

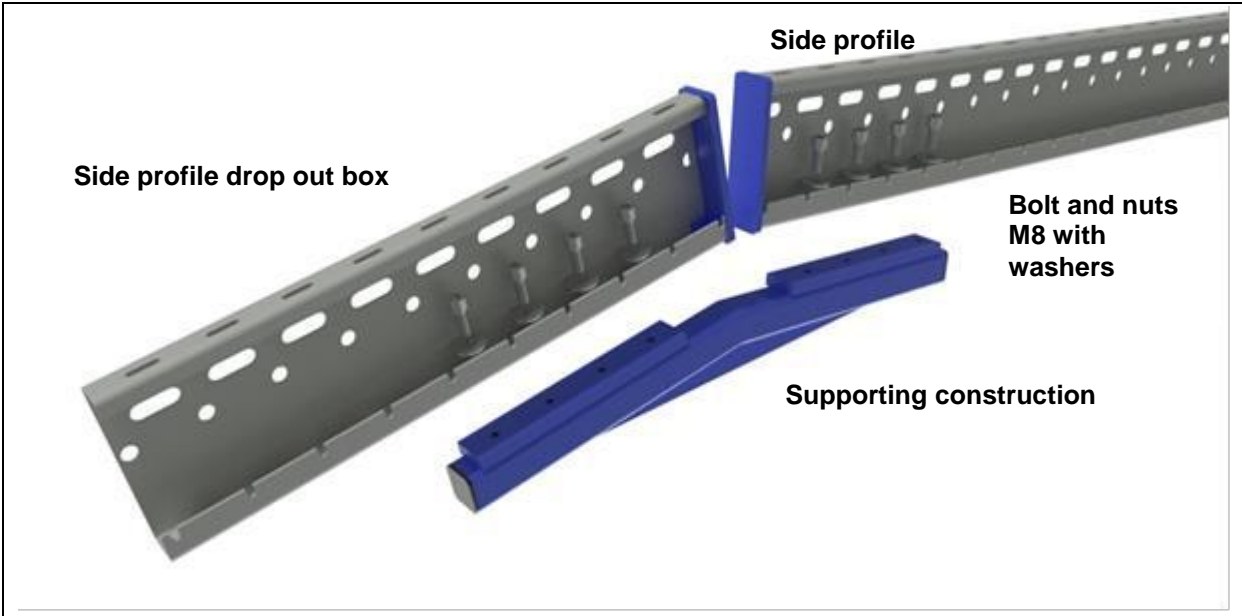

First, the substructure is screwed with the 4 screws M8 on both sides of the side profile. Before that, it is mandatory to press the end plugs in the side profile as well as in the drop out box side profile. After that, the side profile drop out box is also screwed on both sides with the 4 screws M8 to the substructure.

Then the picking tray is inserted and secured with the supplied locking bars.

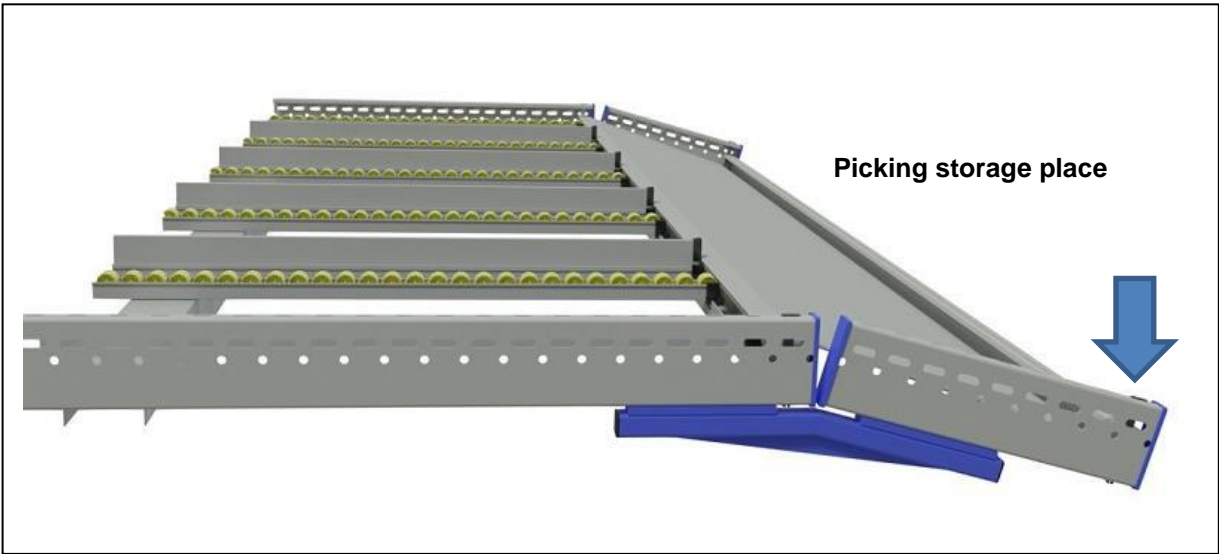

Step 5 Installation of the wheel rails and guide rails

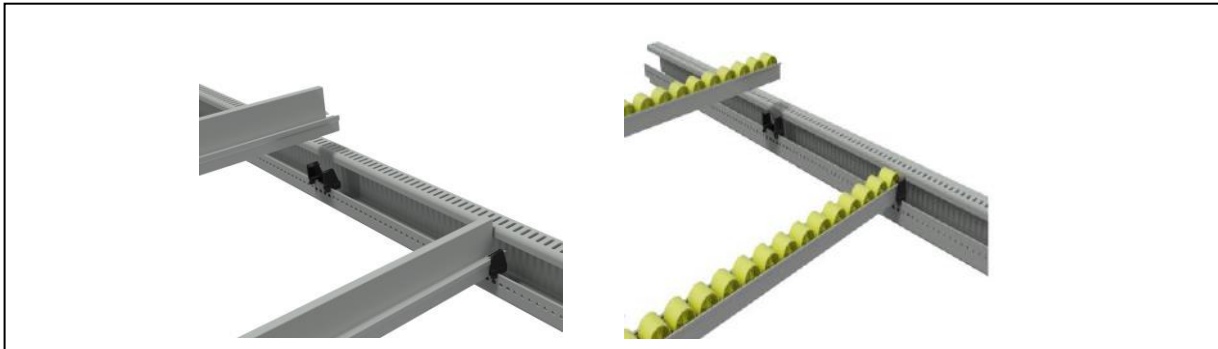

The roller tracks and guide rails are inserted into the already built-in clips, in the loading and unloading profile. It is important to ensure that the guide rail for the standard FIFO system has a clinch on the unloading side.

5. Initial start-up

Once the installation has been successfully made the flow bed can be put into operation. In this respect, pay attention to the points listed below.

5.1 Measures before initial start-up

- Remove any foreign objects in the picking flow rack.
- Note that there are no visible damage on the picking flow rack
- Check the function of the individual components, e.g., the wheel rails are in parallel position.
- Check the tightness of the screw connections
- Clips are properly secured.
- Fixing bolts are properly installed
- The protection devices are all attached. It is forbidden to remove the end caps.
- Quality of the carrier, for example, inherent rigidity and roll ability for cartons.

5.2 Commissioning

- Before operation, check that all responsible staff of conveyor systems are trained on the use of the picking flow rack.
- The setting (configuration) must be strictly adhered to the conveyor system.
- Each configuration setting should be calculated using accurately the tests.

5.3 Commissioning with load

- General function test of the conveyor system
- The slope has been adapted to the respective carrier and its weight
- Move the picking flow bed preferably with small loads
- Check the running of the conveyed material
- Driving of all the transport variants

- Check the clean running

5.4 Ongoing operation



The operation of the conveyor must only take place, if the regulations for safety in the chapter "**Pt. 1.2. specific safety instructions**" and "**Pt. 1.2.1. intended use**" are observed and complied with.

5.5 Loading

- The loading is usually done by hand.
- Do not interfere the flow bed level with your hands.
- Caution, do not put your fingers under the carriers.
- Do not introduce the carriers, if increased pressure is required.
- Comply with the loading direction, depending on the operating mode of the flow bed level (LIFO or FIFO).

6. Cleaning, Maintenance and Repair

The following instructions must be observed for a high availability of the system at standstill of the flow bed.

6.1 Cleaning



Attention!

Maintenance, cleaning and repair work must be only performed by authorized staff or companies.

6.2 Note on maintenance and repair work



Before any maintenance operation, observe the safety instructions!

Before carrying out any maintenance work keep in mind the following points:

- Compliance with the current safety regulations for this area of work, in accordance to use conveyor systems, as well as the welding and the grinding.
- Technical parameters according to order confirmation.
- Set a large security area around the working place. Take also into account the height of the shelf box.
- Provide a good lighting of the workspace.
- Secure the working area with a barrier tape.
- The flow rack level must be necessarily emptied.
- At the end of the maintenance procedure, a visual inspection of the maintenance or repair area must be carried out.
- Do not leave any tools or foreign objects through which the conveyor system



could lose their ability to function

- Only use original Euroroll spare parts.

The specified maintenance intervals apply for the use of the conveyor system in single-shift operation. Shorten the maintenance intervals in case of severe conditions or multi-shift operation.



Evidence of damage in case of improper cleaning

- Do not use harsh cleaners, pressure washer, or means that could damage the picking flow rack or oxidize it.
- Clean the flow rack level and all components only with a dry cloth.

6.3 Maintenance and inspection list

To ensure trouble-free and optimal operation of the picking flow racks, all damaged parts and components must be necessarily replaced.

Order picking flow racks are basically maintenance-free. Nevertheless, the function of the individual parts and components should be checked at regular intervals (see Maintenance and Inspection Plan).

Assembly or components	Activity	Interval					Indications
		d	w	m	s	y	
Order picking flow racks	Visual inspection for external damage	x					Repair damage, if necessary install spare parts
Side profile locking device	Visual inspection for external damage	x					Check correct installation
Screw connections	Check for tight fit			x			Tightening min.49 Nm
Fastening clip in loading and unloading Profile	Check that the clip is intact. Check for tight fit	x					Visual inspection for broken clips. Otherwise replace with new Euroroll clip
Wheel Rails	Check operability	x					Check operability with a carrier. Otherwise replace it with a new wheel rail
End plugs in both side profiles	Visual inspection for external damage. Check for tight fit	x					Check correct installation; if necessary replace the end plugs
Screw connections	Check for tight fit			x			If necessary retighten

Legend: d = daily
w = weekly
m = monthly
s = six-monthly
y = yearly

7. Decommissioning



In case of end or interruption of work on the conveyor system, the picking flow rack must be secured against unauthorized use.



Attention!

The dismantling and disposal can be carried out only by authorized and trained staff or companies.



Protect the environment!

The handling and disposal of old devices are subjected to legal regulations.

8. Spare parts

Instructions for the spare and wearing parts lists



Make sure of the completeness of your spare parts supply

This ensures:

- faster repair
- low repair costs
- high system availability

This avoids:

- long shutdowns
- high repair costs

For a fast and correct handling of your spare parts order, we require the following information:

1. Designation of the system
2. Construction year
3. Order confirmation number (R-)
4. Position number
5. Name and possibly drawing / product no.
6. Order quantity
7. Delivery address

The spare and wearing parts lists are annexed to the respective drawings.

9. Remaining risks

	Risk description	Risk reduction by
	<p>The movement of the transported material can cause severe bruising between conveyed and fixed construction elements.</p>	<p>Staff training</p>

Annex

Drawings

Please consider the Copyright according to ISO 16016:

Reproduction and duplication of this document and utilisation and communication of its content is prohibited, unless with EUROROLL express permission. Infringements will lead to compensation.

We reserve all rights in respect of the issuing of patents or registration of commercial samples.