

Case Study „Automatic Unloading“

euroroll

Facts

Client:	Electronic industry
Device:	Automated guided vehicle (AGV)
Pallets:	Custom designed pallets and stillages
Total pallet positions:	1368
Transport direction:	Longway
Length of the lane:	7840mm (6 pallets deep)
width of the lane / overall width:	872mm/878mm
Pitch:	78mm
Remarks:	Loading and unloading by AGV Fire protection cladding Sprinkler system inside racking

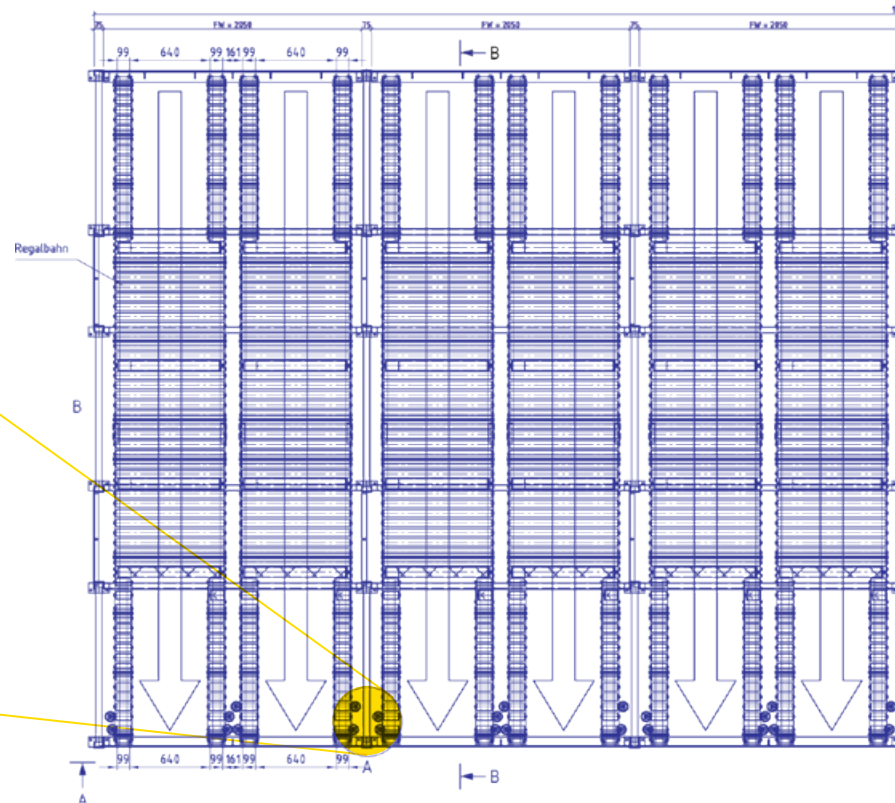
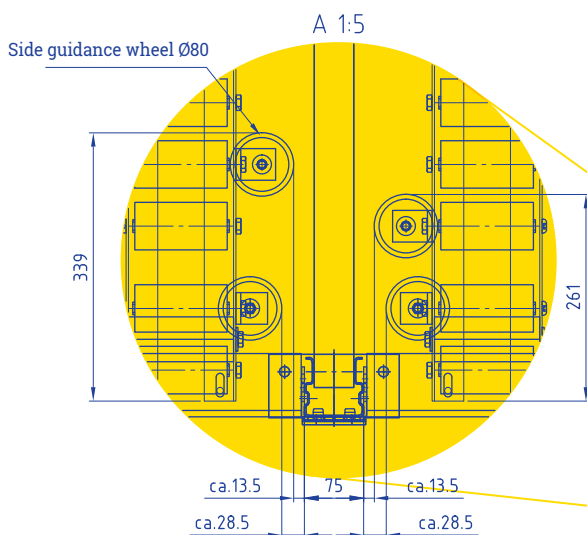

Case Study “Automatic Unloading”



Pallet flow systems for Automated guided vehicle systems

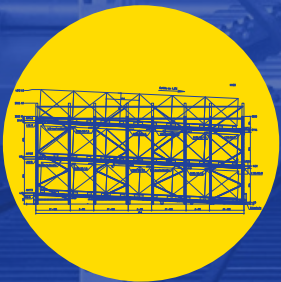

Gravity roller conveyors from Euroroll can also be used with AGV'S. The loading and unloading of the pallets is automated. This system can not only be loaded with standard Euro pallets, but also with Customized pallets, Steel Stillages and plastic pallets. The configuration of the roller tracks was made in close cooperation with the AGV manufacturer, to ensure a smooth and reliable operation. The integration of a sprinkler system and a full enclosure with Fire-protective cladding, have also been integrated.

